

STATE OF MARYLAND

MARYLAND JUDICIARY

ADMINISTRATIVE OFFICE OF THE COURTS

**MARYLAND JUDICIAL CENTER
580 TAYLOR AVENUE, 4TH FLOOR
ANNAPOLIS, MARYLAND 21401**

REQUEST FOR BID

NO. K09-9077-12

**22 – ALLSTEEL WORKSTATIONS DELIVERY AND INSTALLATION
AT HARFORD COUNTY CIRCUIT COURT**

Date of Issuance: MAY 18, 2009
Bid Due Date and Time: MAY 27, 2009: 12:00 P.M.

WARNING: Prospective Offerors who have received this document from a source other than the Issuing Office should immediately contact the Issuing Office and provide their name and mailing address so that amendments to the RFP or other communications can be sent to them. A prospective Offeror who fails to notify the Issuing Office with this information assumes complete responsibility in the event that they do not receive communications from the Issuing Office prior to the closing date.

TABLE OF CONTENTS

I.	Objectives and General Information.....	1
II	Specifications.....	7
III	Evaluation and Selection Procedures.....	12
	Price Proposal Work Sheet.....	11
	Signature Page.....	12

Appendices

- Appendix A: Mandatory Terms and Conditions
- Appendix B: Bid / Proposal Affidavit
- Appendix C: Conflict of interest
- Appendix D: Contract Affidavit
- Appendix E: Product Specifications

**SECTION I
GENERAL INFORMATION**

A. No Obligation

This inquiry implies no obligation on the part of the State of Maryland or the Maryland Judiciary.

B. Respondent's Agent

This Bid must be signed by an owner, partner, or in the case of the corporation, the President, Vice President, Secretary, or other corporate officer(s). To be signed by any other official, a Power of Attorney must be attached to the bid.

Your signature on the signature page of this bid form hereby provides the State of Maryland - Maryland Judiciary your acknowledgment and acceptance of these "Conditions" and the execution of same during the discharge of any succeeding contract.

It shall be clearly understood that by submitting a bid in response to this solicitation, a bidder shall be deemed to have accepted all terms, conditions and requirements set forth in these specifications, terms and general conditions, unless otherwise clearly noted and explained in its bid.

C. Procurement Office Mailing Address

**Proposals shall be addressed to:
ATTN: Karen Hoang
Procurement and Contract Administration
Administrative Office of the Courts
580 Taylor Avenue, 4th Floor
Annapolis, Maryland 21401**

D. Questions/Inquiries

The sole point of contact in the Maryland Judiciary for purposes of this RFB is the Procurement Officer, Karen Hoang of the Procurement and Contract Administration Department.

All questions shall be submitted in writing to **Karen Hoang (410-260-1582) or Sophie Dimbunu** (410-260-1263) and must be received no later than five (5) days prior to the bid due date. Written responses shall be provided. Questions will be accepted by FAX at (410) 260-1749 or e-mail to karen.hoang@mdcourts.gov

E. Closing Date

One (1) original of the proposal shall arrive at the aforementioned office on or before **May 27, 2009, no later than 12:00 P.M.**, in order to be considered. Offerors who mail proposals should allow sufficient mail delivery time to ensure timely receipt by the Procurement Office. Proposals or unsolicited amendments to proposals arriving after the closing time and date.

will not be considered. Bids are to be marked **RFB No. K09-9077-12; Allsteel Workstations Delivery and Installation at Harford County Circuit Court**, on the outside of the envelope.

F. Pre-Bid Conference and Site Visit

Not applicable

G. Bid Opening

The Procurement Office shall hold all bids and modifications in a secure place until the due date, after which time the bids and modifications, if any, will be opened in the presence of at least two State employees and a register of bids as well as bid tabulation will be prepared.

H. Duration of Bid Offer

Bids shall be valid and irrevocable for 180 days following the closing date for this Solicitation. This period may be extended by written agreement between an Offeror and the AOC Procurement Officer.

I. Addenda to the Solicitation

If the AOC Procurement Officer finds it necessary to revise any part of this RFB, an addendum will be provided to all contractors known to have received the RFB. Acknowledgment of the receipt of all amendments, addenda, and changes if issued shall be returned to the Procurement Officer, in writing, with the solicitation.

J. Cancellation of RFB

The AOC Procurement Officer may cancel this RFB, in whole or in part, at any time before the opening of the solicitation.

K. Incurred Expenses

Neither the State or the AOC or any of their officers or employees shall be responsible for any cost incurred by any Offeror in preparing and/or submitting a proposal.

L. Economy of Preparation

Bids should be prepared simply and economically, providing a concise and straightforward description of the Contractor's offer to meet the requirements set forth in the RFB.

M. Public Information Act Notice

An offeror should identify those portions of its bid that it considers confidential, proprietary commercial information or trade secrets, and provide, upon request, justification why such materials, if requested, should not be disclosed by the State under the Access to Public Records Act, Title 10, Subtitle 6, of the State Government Article of the Annotated Code of Maryland. Offerors are

advised that, upon request for this information from a third party, the Procurement Officer will be required to make an independent determination whether the information may be disclosed.

N. Subcontractors

The AOC will enter into an agreement with the selected offering Contractor(s) only. The selected Contractor(s) shall be responsible for all products and services as required by this Solicitation. Subcontractors, if any, shall be identified and a complete description of their role relative to this proposal shall be included at the time of the proposal opening.

O. Type of Contract

The contract resulting from this Solicitation will be a fixed-price contract.

P. General Contractual Conditions

Any contract resulting from this RFB will contain the general provisions included in Appendix 1. Additionally, this RFB, including the Scope of Work, and the successful Offeror's bid will be incorporated by reference and made a part of the contract.

Q. Bid/Proposal Affidavit

Each bid shall include a completed Bid/Proposal Affidavit. A copy of the affidavit is included in Appendix 2 of this RFB.

R. Conflict of Interest Affidavit and Disclosure

All prospective vendors that submit a response to this solicitation shall complete Appendix 3 to this solicitation, titled *Conflict of Interest Affidavit and Disclosure*. In this solicitation the term "Conflict of interest" means that, because of other activities or relationships with other persons: (i) A person is unable or potentially unable to render impartial assistance or advice to the State;

(ii) The person's objectivity in performing the contract work is or might be otherwise impaired; or (iii) A person has an unfair competitive advantage.

Offerors should be aware that if the procurement officer makes a determination before award that facts or circumstances exist giving rise or which could in the future give rise to a conflict of interest, the procurement officer may reject a bid or offer and that after award, the State may terminate the contract, in whole or in part, if it considers termination necessary to avoid an actual or potential conflict of interest. If the contractor knew or reasonably could have been expected to know of an actual or potential conflict of interest before or after award and did not disclose it or misrepresented relevant information to the procurement officer, the State may terminate the contract for default, institute proceedings to debar the contractor from further State contracts, or pursue other remedies as may be permitted by law or the contract. If the conflict of interest involves an employee of the judiciary, disciplinary action may be taken against the employee.

S. Contract Affidavit

Offerors are advised that if a contract is awarded as a result of this Solicitation, the successful Offeror will be required to complete a Contract Affidavit. A copy of this Contract Affidavit is included in **Appendix 4** for information purposes only. The Contract Affidavit is not required to be submitted with this proposal. The terms set forth in the Contract Affidavit are mandatory and not subject to negotiation.

T. Minority Business Enterprises

Minority Business Enterprises are encouraged to respond to this solicitation notice. It is the goal of the Maryland Judiciary that certified minority business enterprises participate on Judiciary's supply, maintenance, general miscellaneous and service procurements.

An MBE subcontract participation goal of Zero percent (0%) of the total current amount has been established for this procurement. By submitting a response to this solicitation, the bidder or offeror agrees that this amount of the contract will be performed by minority business enterprises.

If this solicitation carries an MBE subcontractor participation goal (see above paragraph), respondents are required to submit as part of the bid proposal package the following forms:

MJ-EE0-03 – Schedule for participation of Minority Business Enterprise

MJ-EE0-04 – Minority Contractor Project Disclosure and Participation Statement

SECTION II SPECIFICATIONS

1. General

Contractor shall deliver and install 22 Allsteel workstations as described below at Harford County Circuit Court, 20W. Courtland Street, 1st Floor, Bel Air, MD 21014.

The work shall be performed in accordance with below specifications as well as per Maryland Judiciary's Terms and Conditions. **Bids will be evaluated and reviewed based on the best layout area.**

2. Contractors Responsibilities

A. Statement of Work

The Contractor shall supply, deliver and install 22 workstations in the designs and qualities specified according to this Request For Bid. **The workstations must be Allsteel to match existing workstations.** Contractor has to be aware of the fact that the installation will be in a building under construction; and that there is limited access to the elevator, therefore the Vendor must coordinate and schedule installation with General Contractor.

The specification, design and qualities of workstations are herewith below;

B. Equipment / workstation full details

Quantity

Description

(NO SUBSTITUTIONS)

Twenty-Two (22) Allsteel workstations to match existing workstations, includes four larger supervisors workstations with guest seating. All workstations to offer a minimum of:

- 2630 square inches of work surface space, including a radius leading edge corner for ergonomic computer access.
- 66 linear inches of overhead storage, with tack boards and task lights.
- Combination of 82" and 69" high panels.
- Minimum of 1 BBF pedestal per workstation.
- Full electric with four circuits and one totally isolated circuit.
- All panels must be stack-on capable, with up to three stack-on segments possible

- and remaining totally structural capable.

- All panels must be fully acoustic.
- Panel top caps must be offered in wood, metal, and cableway, and changeable in the field.
- Lateral files must be available and used in the layout, with a matching range of drawer pulls for all pedestals.
- One synchronized chair per workstation.

C. Contractor's Qualifications

Contractor shall have at least one (1) year experience in installation of workstations.

D. Delivery

Complete final delivery and installation shall be accomplished on or before August 30, 2009. Any exceptions to this delivery requirement must be clearly stipulated.

INSIDE DELIVERY IS REQUIRED to the following location;

Circuit Court for Harford County
20W. Courtland Street, 1st Floor
Bel Air, MD 21014
Attn: James J. Reilly

3. Estimated Quantities

AOC reserves the right to increase or decrease the number of units as required. Quantities are approximate and the unit rate bid shall apply regardless of any increase or decrease in the estimated quantities shown herein

4. Duration of the Contract

Once awarded, the Contract shall remain in force until the delivery is complete on or before **August 30, 2009**.

5. Maryland Judiciary's Responsibilities

The Maryland Judiciary will provide vendor with all information needed to deliver and install (22) Allsteel workstations at Harford Circuit Court.

6. Payment

Subject to the delivery and installation of the merchandise and its acceptance by the AOC, successful respondent may invoice the AOC for all appropriate charges for the merchandise delivered. All such charges shall be derived in accordance with the prices originally quoted on

the bid worksheet, attached hereto and made part hereof. In the event that successful respondent is not in default of any of the Contract Terms and Conditions, then AOC shall cause said invoice to be timely paid.

7. Indemnification of Maryland Judiciary

The Contractor shall indemnify the AOC and the Judiciary against liability for any costs, expenses, loss, suits, actions or claims of any character arising from or relating to the performance of the Contractor or its subcontractors under this Contract.

The AOC and Judiciary have no obligation to provide legal counsel or defense to the Contractor or its subcontractors in the event that a suit, claim of any character is brought by any person not party to this contract against the Contractor or its subcontractors as a result of or relating to the Contractor's obligations under this Contract.

The AOC and Judiciary have no obligation for the payment of any judgments of the settlement of any claims against the Contractor or its subcontractors as a result of or relating to the Contractor's obligations under this Contract.

The Contractor shall immediately notify the Procurement Officer of any claim or suit made or filed against the Contractor or its subcontractors regarding any matter resulting from or relating to the Contractor's obligations under the Contract, and will cooperate, assist and consult with the State in defense or investigation of any claim, suit, or action made or filed against the State as a result of or relating to the Contractor's performance under this Contract.

The Contractor agrees to indemnify, protect and save harmless AOC, its officers, agents and employees with respect to any claim, action, cost or judgment for patent infringement, arising out of purchase or use of materials, supplies, equipment or services covered by this Contract.

8. Insurance Requirements

The Contractor shall at all times during the term of the Contract maintain in full force and effect the policies of insurance required by this Section. The Contractor, if requested by AOC, shall provide certified true copies of any and all of the policies of insurance to AOC.

Evidence that the required insurance coverage has been obtained may be provided by Certificates of Insurance duly issued and certified by the insurance company or companies furnishing such insurance. Such evidence of insurance must be delivered to the AOC Office of Procurement before the actual implementation of the Agreement.

The Insurance Certificate mentioned hereinabove must be received by the AOC Office of

Procurement within ten (10) days of the notice of intent to award the Contract. In the event the Insurance Certificate is not received within ten (10) days after the date of the notice of intent to

award, or if such certificate is insufficient respecting the limits and scope specified herein, then the AOC Office of Procurement reserves the right to award the Contract to another respondent. **Time is of the essence.**

All insurance policies required by this section, or elsewhere in the Contract, shall be so endorsed as to provide that the insurance carrier will be responsible for giving immediate and positive notice to AOC in the event of cancellation or restriction of the insurance policy by either the insurance carrier or the successful respondent, at least sixty (60) days prior to any such cancellation or restriction. Said insurance policies shall name as an additional insured the Administrative Office of the Courts and the Maryland Judiciary.

Please note that the limits required below may be satisfied by either individual policies or a combination of individual policies and an umbrella policy. The requiring of any and all insurance as set forth in these specifications, or elsewhere, shall be in addition to and not in any way in substitution for all the other protection provided under the Contract.

No acceptance and/or approval of any insurance by AOC, or the Manager of Procurement, shall be construed as relieving or excusing the Contractor from any liability or obligation imposed upon it by the provisions of the Contract.

A. WORKER'S COMPENSATION

1. The Contractor shall maintain Worker's Compensation insurance as required by the laws of the State of Maryland and including Employer's Liability coverage with a minimum limit of \$500,000-each accident; \$500,000 disease-each employee; and \$500,000 disease-policy limit.

B. LIABILITY INSURANCE

Occurrence forms of comprehensive general liability insurance covering the full scope of this agreement with limits not less than \$1,000,000 per occurrence and \$2,000,000 aggregate for personal or bodily injuries and \$1,000,000 per occurrence and aggregate for property damage. A combined single limit per occurrence of \$2,000,000 is acceptable. All policies issued shall include permission for partial or total occupancy of the premises by or for the Administrative Office of the Courts within the scope of this Contract. Such insurance shall include but shall not be limited to, the following:

1. Comprehensive general liability insurance including a comprehensive broad form endorsement and covering: a) all premises-operations, b) completed operations, c) independent Contractors, d) liability assumed by oral or written contract or agreement, including this contract, e) additional interests of employees, f) notice of occurrence, g) knowledge of occurrence by specified official, h) unintentional errors and omissions, i) incidental (contingent) medical malpractice, j) extended definition of bodily injury, k) personal injury coverage (hazards A and B) with no exclusions for liability assumed contractually or injury sustained by

employees of Contractor, 1) broad form coverage for damage to property of the Administrative Office of the Courts,

as well as other third parties resulting from completion of the Contractor's services.

2. Comprehensive business automobile liability insurance covering use of any motor vehicle to be used in conjunction with this contract, including hired automobiles and non-owned automobiles.

C. COMPREHENSIVE AUTOMOBILE LIABILITY

Limit of Liability - \$ 1,000,000 Bodily Injury
\$ 1,000,000 Property Damage

In addition to owned automobiles, the coverage shall include hired automobiles and non-owned automobiles with the same limits of liability.

D. SCOPE OF INSURANCE AND SPECIAL HAZARDS

The insurance required under sub-paragraphs (A),(B), (C) and (D) above shall provide adequate protection for the Contractor against claims which may arise from the Contract, whether such claims arise from operations performed by the Contractor or by anyone directly or indirectly employed by him, and also against any special hazards which may be encountered in the performance of the Contract. In addition, all policies required must not exclude coverage for equipment while rented to other.

E. SUBCONTRACTOR'S INSURANCE

If any of the work under the Contract is subcontracted, the Contractor shall require subcontractors, or anyone directly or indirectly employed by any of them to procure and maintain the same coverages in the same amounts specified above.

PRICE WORK SHEET

SOLICITATION NO. K09-9077-12

Prices shall include all costs associated with the delivery and installation of the merchandise of this RFB.

(NO SUBSTITUTIONS)

Quantity

Description

22 each

Twenty-Two Allsteel workstations to match existing. Includes four larger supervisors workstations with guest seating

Unit cost: \$ _____ Total cost \$ _____

I HEREBY AFFIRM THAT THE FOREGOING BID PRICES INCLUDE ALL COSTS ASSOCIATED WITH THE PERFORMANCE OF THIS SOLICITATION, INCLUDING, BUT NOT LIMITED TO, SALARIES, WAGES, MATERIALS, EQUIPMENT, SHIPPING, DELIVERY, BID PREPARATION, TRANSPORTATION, OVERHEAD, TAXES AND PROFIT, AND I HAVE LEGAL AUTHORITY TO BIND THE BIDDER TO THE BID PRICES SET FORTH ABOVE.

Bid Compiled By: _____

Title: _____

Company: _____

**AOC SOLICITATION NO. K09-9077-12
SIGNATURE PAGE**

DATE PROPOSAL SUBMITTED:

COMPANY OF RESPONDENT (Print or Type):

NAME/TITLE OF RESPONDENT (Print or Type):

ADDRESS OF RESPONDENT (Print or Type):

TELEPHONE _____ FACSIMILE _____

FEDERAL TAX I.D. NO. OR SOCIAL SECURITY NO. _____

SIGNATURE OF RESPONDENT

ACCEPTED FOR AOC _____

APPENDICES

Contract no. K09-9082-40

Appendix 1

**Mandatory Terms and Conditions for Contracts
Administrative Office of the Courts (AOC)**

This Contract is made this _____ day of _____ 200____, by and between the

State of Maryland, Administrative Office of the Courts (the “State” or “AOC”) and Name of contracting business (*The “Contractor”*).

In consideration of the mutual covenants and promises herein contained and other good and valuable consideration, the receipt and sufficiency of which is hereby acknowledged, the State and the Contractor agree as follows:

1. Scope of Contract

in 1.1 The Contractor shall provide xxxxxxxxx as described in the attached agreement accordance with the terms and conditions of this Contract and the Exhibits attached to this Contract and incorporated as part of this Contract:

- Exhibit A: Contract Affidavit
- Exhibit B: Solicitation (Request for Bids/Proposals or Request for Quote)
- Exhibit C: Contractor’s Proposal or Quote (includes technical and price proposal)

1.2 If there are any inconsistencies between the contract and any of the Exhibits, the terms of this Contract shall prevail. If there are any inconsistencies between Exhibits B and C, Exhibit B shall prevail.

1.3 The Procurement Officer may, at any time, by written order, make changes in the work within the general scope of the Contract.

1.4 Except as otherwise provided in this Contract, if any change causes an increase or decrease in the Contractor’s cost of, or the time required for, the performance of any part of the work, whether or not changed by the order, an equitable adjustment in the Contract price shall be made and the Contract modified in writing accordingly. The Contractor must assert in writing its right to an adjustment under this section within thirty days (30) of receipt of a written change order and shall include a written statement setting forth the nature and cost of such claim. No claim by the Contractor shall be allowed if asserted after final payment under this Contract.

Failure to agree to an adjustment under this section shall be a dispute under the Disputes clause. Nothing in this section shall excuse the Contractor from proceeding with the Contract as changed.

2. Term of The Contract

Once awarded, the Contract shall remain in force for a period not to exceed xx (xx) years from the date of execution. Upon expiration of the Contract, or upon its earlier termination as provided herein, the AOC reserves the right to rebid or to extend for xx additional xx (x) year periods at its sole option.

AOC, in its sole discretion, may grant an adjustment in the total value of the Contract to allow for inflationary increases for the extension periods provided, however, that any requested increase does not exceed three percent (3%) or the consumer price index (U.S. Bureau of Labor Statistics - All Urban Consumers), whichever is lower.

3. Consideration and Payment

- 3.1 The Contractor shall be compensated for xxx. The total price for the goods/services to be provided by Contractor under the contract shall be **xx dollars (\$)**.
- 3.2 Payments to the Contractor pursuant to this Contract shall be made no later than thirty days after the acceptance of the support services and receipt of a proper invoice from the Contractor. Each invoice for services rendered must reflect the Contractor's federal tax identification number. Charges for late payment of invoices are prohibited.
- 3.3 In addition to any other available remedies, if in the opinion of the Procurement Officer, the Contractor fails to perform in a satisfactory and timely manner, the Procurement Officer may refuse or limit approval of any invoice for payment, and may cause payments to the Contractor to be reduced or withheld until such time as the Contractor meets performance standards as established by the Procurement Officer in accordance with this Contract. The final Contract payment will not be made until after certification is received from the Comptroller of the State that all taxes have been paid.

4. Definitions [*Only use this section or portions thereof, if applicable to purchase involved*].

For the purpose of this Agreement, the following definitions shall apply:

- 4.1 "Materials" means reports, programs, documentation, models, methods, techniques, presentations, drawings, studies, specifications, estimates, tests, software, designs, graphics, computations, and data provided by the Contractor.
- 4.2 "Products" means (i) a machine, its features, conversions, upgrades, elements or accessories, or any combination of them, provided by the Contractor, and (ii) any of the following provided by the Contractor: machine readable instructions, a collection of machine readable data, such as a database; and related license Materials, including documentation and listings, in any form.
- 4.3 "System" means the system as provided by this Agreement
- 4.4 "Type I Materials" means Material that is created under this Agreement.
- 4.5 "Type II Materials" means Material existing before this Agreement, or

developed during, but independent of this Agreement, in which the Contractor or third parties have all right, title, and interest.

5. Ownership and Rights in Data

Section 5 applicable _____ or non-applicable _____ [*the language in this section applies to software, computer engineering and related situations. It would not be applicable in situations involving the purchase of furniture and related items for example*].

5.1

The Contractor agrees to furnish the AOC with copies of the following (all of which, for purposes of this Agreement, shall be deemed Type I Materials): computations, computer files, data, model(s), transmittal letters, response letters, and all other documents or correspondence pertinent to the operation of the System produced or received as part of this Agreement. In addition, all hardware and Type I software necessary to the System's performance in accordance with the terms of this Agreement are, and shall remain, the exclusive property of the AOC. Licenses for all Type II Materials (e.g., "off the shelf" software) shall be provided to the AOC with all rights to use the Type II Materials. The Contract shall provide to the AOC copies of all end user software licensing agreements for all Type II Materials, which licensing agreements shall be in accordance with the OEM's standard software license, paid-up licenses through the maintenance period (no upgrades included thereafter), and provided at no additional cost to the AOC. Nothing in this Agreement shall prevent the Contractor from utilizing any general know-how, techniques, ideas, concepts, algorithms, or other knowledge acquired or developed during the performance of this Agreement on behalf of itself and its future customers.

5.2 The AOC shall be the owner of all Type I Materials and shall be entitled to use them without restriction and without compensation to the Contractor other than specifically provided in this Agreement. The Contract shall have no liability or responsibility for use of the Type I Materials by the AOC beyond their specified use as part of the System as provided by the Contractor in accordance with this Agreement. The Contractor may retain one copy of the Type I Materials, but may not, without prior written consent of the AOC, be entitled to use, execute, reproduce, display, perform, distribute (internally or externally) copies of, or prepare derivative works based on Type I Materials or authorize others to do any of the former. The AOC may duplicate, use, and disclose in any manner and for any purpose whatsoever, and allow others to do so, all Type I Materials.

5.3 The Contractor agrees that, at all times during the terms of this Agreement and thereafter, the Type I Materials shall be "works for hire" as that term is

interpreted under U.S. copyright law. To the extent that any Type I Materials are not works for hire for the AOC, the Contractor hereby relinquishes, transfers, and assigns to the AOC all of its rights, title, and interest (including all intellectual property rights) to all such Type I Materials created under this Agreement, and will cooperate with the AOC in effectuating and registering any necessary assignments.

5.4 The AOC shall retain full ownership over any materials that it provides to the Contractor under this Agreement.

6. Warranties The Contractor hereby represents and warrants that:

- 6.1 It is qualified to do business in the State of Maryland and that it will take such action as, from time to time, may be necessary to remain so qualified;
- 6.2 It is not in arrears with respect to the payment of any monies due and owing the State of Maryland, or any department or unit thereof, including but not limited to the payment of taxes and employee benefits, and that it shall not become so in arrears during the term of this Contract;
- 6.3 It shall comply with all federal, State and local laws applicable to its activities and obligations under this Contract;
- 6.4 It shall obtain, at its expense, all licenses, permits, insurance, and governmental approvals, if any, necessary to the performance of its obligations under this Contract;

7. Patents, Copyrights

- 7.1 If the Contractor furnishes any design, device, material, process, or other item that is covered by a patent or copyright or which is proprietary to or a trade secret of another, the Contractor shall obtain the necessary permission or license to use such item or items.
- 7.2 The Contractor will defend or settle, at its own expense, any claim or suit against the State alleging that any such item furnished by the Contractor infringes any patent, trademark, copyright, or trade secret. The Contractor also will pay all damages and costs that by final judgment might be assessed against the State due to such infringement and all attorney fees and litigation expenses reasonably incurred by the State to defend against such a claim or suit.
- 7.3 If any products furnished by the Contractor become, or in the Contractor's opinion are likely to become, the subject of a claim of infringement, the

Contractor will, at its option and expense: a) procure for the State the right to continue using the applicable item, b) replace the product with a non-infringing product substantially complying with the item's specifications, or c) modify the item so that it becomes non-infringing and performs in a substantially similar manner to the original item.

7.4 If the Contractor obtains or uses for purposes of this Contract any design, device, material, process, supplies, equipment, text, instructional material, services or other work, the Contractor shall indemnify the State, its Officers, agents, and employees with respect to any claim, action, cost, or judgment for patent, trademark, or copyright infringement, arising out of the possession or use of any design, device, material, process, supplies, equipment, text, instructional material, services or other work covered by any Contract awarded.

8. Non-hiring of Employees No employee of the State of Maryland or any unit hereof whose duties as such employee include matters relating to or affecting the subject matter of this Contract shall, while so employed, become or be an employee of the Contractor.

9. Disputes Any claim regarding the proper interpretation of this agreement shall be submitted, in writing, to the procurement officer, together with a statement of grounds supporting the Contractor's interpretation. Pending resolution of a claim by the Procurement Officer, the Contractor shall proceed diligently with the performance of the Contract in accordance with the Procurement Officer's decision. [*An adverse decision to the Contractor may be appealed by the Contractor to the Appeals Board, within 15 days of issuance*].

10. Maryland Law The place of performance of this Contract shall be the State of Maryland. This Contract shall be construed, interpreted, and enforced according to the laws of the State of Maryland, including State Government Article 12-204.

11. Amendments Except as provided in section 2, any amendment to this Contract must first be approved in writing by the Procurement Officer, subject to any additional approvals required by State law and the Judiciary's Procurement Policy.

12. Non-discrimination in Employment The Contractor agrees: (a) not to discriminate in any manner against an employee or applicant for employment because of race, color, religion, age, sex, marital status, national origin, disability, familial status, genetic information, and sexual orientation; (b) to include a provision similar to that contained in subsection (a), above, in any underlying subcontract; and (c) to post and to cause subcontractors to post in conspicuous places available to employees and applicants for employment, notices setting forth the substance of this clause.

13. Contingent Fee Prohibition The Contractor warrants that it has not employed or retained any person, partnership, corporation, or other entity, other than a bona fide employee, bona fide agent, bona fide salesperson, or commercial selling agency working for the Contractor to solicit

or secure this agreement, and that it has not paid or agreed to pay any person, partnership, corporation, or other entity, other than a bona fide employee, bona fide salesperson, or

commercial selling agency, any fee or other consideration contingent on the making of this agreement.

14. Non-availability of Funding If the General Assembly fails to appropriate funds or if funds are not otherwise made available for continued performance for any fiscal year of this Contract succeeding the first fiscal year, this Contract shall be canceled automatically as of the beginning of the fiscal year for which funds were not appropriated or otherwise made available; provided, however, that this will not affect either the State's rights or the Contractor's rights under any termination clause in this Contract. The effect of termination of the Contract hereunder will be to discharge both the Contractor and the State from future performance of the Contract, but not from their rights and obligations existing at the time of termination. The Contractor shall be reimbursed for the reasonable value of any non-recurring costs incurred but not amortized in the price of the Contract. The State shall notify the Contractor as soon as it has knowledge that funds may not be available for the continuation of this Contract for each succeeding fiscal period beyond the first.

15. Termination for Cause If Contractor fails to fulfill its obligations under this Contract properly and on time, or otherwise violates any provision of the Contract, the State may terminate the Contract by written notice to the Contractor. The notice shall specify the acts or omissions relied upon as cause for termination. All finished or unfinished work provided by the Contractor shall, at the State's option, become the State's property. The State shall pay the Contractor fair and equitable compensation for satisfactory performance prior to receipt of notice of termination, less the amount of damages caused by the Contractor's breach. If the damages are more than the compensation payable to the Contractor, the Contractor will remain liable after termination and the State can affirmatively collect damages.

16. Termination for Convenience The performance of work under this Contract may be terminated by the State in accordance with this clause in whole or, from time to time, in part whenever the State shall determine that such termination is in the best interest of the State. The State will pay all reasonable costs associated with this Contract that the Contractor has incurred up to the date of termination, and all reasonable costs associated with termination of the Contract; however, the Contractor shall not be reimbursed for any anticipatory profits that have not been earned up to the date of termination.

17. Delays and Extensions of Time The Contractor agrees to perform this agreement continuously and diligently. No charges or claims for damages shall be made by the Contractor for any delays or hindrances, regardless of cause, in the performance of services under this Contract. Time extensions may be granted only for excusable delays that arise from unforeseeable causes beyond the control and without the fault or negligence of the Contractor, including but not restricted to acts of God, acts of the public enemy, acts of the State in either its

sovereign or contractual capacity, acts of another Contractor in the performance of a State contract, fires, floods, epidemics, quarantine restrictions, strikes, freight embargoes, or the delay of a subcontractor or supplier arising from unforeseeable causes beyond the control and without the fault or negligence of either the Contractor or the subcontractor or supplier.

18. **Suspension of Work** The State unilaterally may order the Contractor in writing to suspend, delay, or interrupt all or any part of its performance for such period of time

as the Procurement Officer may determine to be appropriate for the convenience of the State.

19. **Pre-existing Regulations** The applicable statutes and regulations of the State of Maryland in effect at the time of this agreement are incorporated in this agreement.

20. **Financial Disclosure** The Contractor shall comply with the provisions of Section 13-221 of the State Finance and Procurement Article of the Annotated Code of Maryland, which requires that every business that enters into contracts, leases, or other agreements with the State of Maryland during a calendar year under which the business is to receive in the aggregate

\$100,000 or more, shall, within thirty (30) days of the time when the aggregate value of these contracts, leases or other agreements reaches \$100,000, file with the Secretary of State of Maryland certain specified information, to include disclosure of beneficial ownership of the business.

21. **Political Contribution Disclosure** The Contractor shall comply with the provisions of Title 14 of the Election Law of Maryland which require that every person that enters into contracts, leases, or other agreements with the State of Maryland, including its agencies, or a political subdivision of the State during a calendar year under which the person receives in the aggregate \$100,000 or more, shall, on or before February 1 of the following year, file with the State Administrative Board of Election Laws certain specified information to include disclosure of political contributions in excess of \$500 to a candidate for elective office in any primary or general election.

22. **Retention of Records** The Contractor shall retain and maintain all records and documents relating to this Contract for three (3) years after final payment by the State hereunder or any applicable statute of limitations, whichever is longer, and shall make them available for inspection and audit by authorized representatives of the State, including the Procurement Officer or the Procurement Officer's designee, at all reasonable times.

23. **Liability for Loss of Data** In the event of loss of any data or records necessary for the performance of this Contract, which such loss is due to the error or negligence of the Contractor, the Contractor shall be responsible, irrespective of cost to the Contractor, for recreating all such lost data or records in a manner, format, and time-frame acceptable to the Department.

24. **Cost and Price Certification** By submitting cost or price information, the Contractor

certifies to the best of its knowledge that the information submitted is accurate, complete, and current as of [*Insert proper date*] . The price under this Contract and any change order or modification hereunder, including profit or fee, shall be adjusted to exclude any significant price increases occurring because the Contractor furnished cost or price information which, as of [*Insert proper date*] was inaccurate, incomplete, or not current.

25. Subcontracting and Assignment The Contractor may not subcontract any portion of the services provided under this Contract without obtaining the prior written approval of the State, nor may the Contractor assign this Contract, or any of its rights or obligations hereunder, without the prior written approval of the State. Any such subcontract or assignment shall be subject to any terms and conditions that the Department deems necessary to protect the interest of the State. The Department shall not be responsible for the fulfillment of the Contractor's obligations to subcontractors.

26. Indemnification

- 26.1 The Contractor shall indemnify the AOC against liability for any suits, actions, or claims of any character arising from or relating to the performance of the Contractor or its subcontractors under this Contract.
- 26.2 The AOC has no obligation to provide legal counsel or defense to the Contractor or its subcontractors in the event that a suit, claim or action of any character is brought by any person not party to this Contract against the Contractor or its subcontractors as a result of or relating to the Contractor's obligations under this Contract.
- 26.3 The AOC has no obligation for the payment of any judgments or the settlement of any claims against the Contractor or its subcontractors as a result of or relating to the Contractor's obligations under this Contract.
- 26.4 The Contractor shall immediately notify the Procurement Officer of any claim or suit made or filed against the Contractor or its subcontractors regarding any matter resulting from or relating to the Contractor's obligations under the Contract, and will cooperate, assist and consult with the AOC in the defense or investigation of any claim, suit, or action made or filed against the AOC as a result of or relating to the Contractor's performance under this Contract.

27. Public Information Act Notice Offerors shall give specific attention to the identification of those portions of their proposals which they deem to be confidential, proprietary information or trade secrets, and provide any justification of why such materials, upon request, should not be disclosed by the State pursuant to ' 10-617(d) of the State Government Article, Annotated Code of Maryland, or other law relating to access to public records. *[Including, Maryland Rules of Procedure, Rules 16-1001 through 16-1011. If a request is made to review any part of a proposal the offer may be contacted, as circumstances allow, to express its views on the*

availability of requested information, however, the final decision on release of any information rests with the Judiciary.]

28. Conflict of Interest

A. "Conflict of interest" means that because of other activities or relationships with other persons, a person is unable or potentially unable to render impartial assistance or advice to the State, or the person's objectivity in performing the contract work is or might be otherwise impaired, or a person has an unfair competitive advantage.

B. "Person" includes a contractor, consultant, or subcontractor or subconsultant at any tier, and also includes an employee or agent of any of them if the employee or agent has or will have the authority to control or supervise all or a portion of the work for which a bid or offer is made.

C. The Contractor warrants that, except as disclosed in § D, below, there are no relevant facts or circumstances now giving rise or which could, in the future, give rise to a conflict of interest.

D. The following facts or circumstances give rise or could in the future give rise to a conflict of interest (explain details-attach additional sheets if necessary):

E. The Contractor agrees that if an actual or potential **conflict of interest** arises after the contract commences, the Contractor shall immediately make a full disclosure in writing to the procurement officer of all relevant facts and circumstances. This disclosure shall include a description of actions which the Contractor has taken and proposes to take to avoid, mitigate, or neutralize the actual or potential conflict of interest. If the contract has been awarded and performance of the contract has begun, the contractor shall continue performance until notified by the procurement officer of any contrary action to be taken. The existence of a conflict of interest is cause for termination of the agreement as well as disciplinary action against an employee for whom a conflict exists.

29. Notices All notices required to be given by one party to the other hereunder shall be in writing and shall be addressed as follows:

State: Raymond Mack, Executive Director
Procurement and Contract Administration
Maryland Judicial Center
580 Taylor Ave.
Annapolis, Maryland 21401

(410) 260-1410

Contractor:

In Witness Whereof, the parties have signed this Agreement this _____ day of _____, 200__.

Approved for form and legal sufficiency, this ____ day of _____, 200__.

David R. Durfee Jr.
Director of Legal Affairs

Contractor

Signature
Authorized Representative

Date: _____

Reviewed:

Frank Broccolina
State Court Administrator
Date: _____

State of Maryland:

Robert M. Bell, Chief Judge
Court of Appeals

Date: _____

Appendix 2

BID/PROPOSAL AFFIDAVIT
ANTI-BRIBERY, NON-COLLUSION, FINANCIAL DISCLOSURE
AND PROCUREMENT AFFIDAVIT

A. AUTHORIZED REPRESENTATIVE

I HEREBY AFFIRM THAT:

I am the [title]_____and the duly authorized representative of [Contractor]_____
_____and that
I possess the legal authority to make the Affidavit on behalf of myself and the Contractor for which I
am acting.

B. AFFIRMATION REGARDING BRIBERY CONVICTIONS

I FURTHER AFFIRM THAT:

Neither I, nor to the best of my knowledge, information, and belief, the above Contractor (as is defined in Section 16-101(b) of the State Finance and Procurement Article of the Annotated Code of Maryland), or any of its officers, directors, partners, or any of its employees directly involved in obtaining or performing contracts with public bodies (as is defined in section 16-101(f) of the State Finance and Procurement Article of the Annotated Code of Maryland), has been convicted of, or has had a probation before judgment imposed pursuant to Article 27, Section 641 of the Annotated Code of Maryland, or has pleaded nolo contendere to a charge of, bribery, attempted bribery, or conspiracy to bribe in violation of Maryland law or of the law of any other state or federal law, except as follows [indicate the reasons why the affirmation cannot be given and list any conviction, plea, or imposition of probation before judgment with the date, court, official or administrative body, the sentence or disposition, the name(s) of persons) involved, and their current positions and responsibilities with the Contractor]:

C. AFFIRMATION REGARDING OTHER CONVICTIONS

I FURTHER AFFIRM THAT:

Neither I, nor to the best of my knowledge, information, and belief, the above Contractor, or any of its officers, directors, partners, or any of its employees directly involved in obtaining or performing contracts with public bodies, has:

(1) been convicted under state or federal statute of a criminal offense incident to obtaining, attempting to obtain, or performing a public or private contract, fraud, embezzlement, theft, forgery, falsification or destruction of records, or receiving stolen property;

(2) been convicted of any criminal violation of a state or federal antitrust statute;

(3) been convicted under the provision of Title 18 of the United States Code for violation of the Racketeer Influenced and Corrupt Organization Act, 18 U.S.C. 1961, et seq., or the Mail Fraud Act, 18 U.S.C. 1341, et seq., for acts arising out of the submission of proposals or proposals for a public or private contract;

(4) been convicted of a violation of the State Minority Business Enterprise Law, Section 14-308 of the State Finance and Procurement Article of the Annotated Code of Maryland;

(5) been convicted of conspiracy to commit any act or omission that would constitute grounds for conviction or liability under any law or statute described in subsection (1), (2), (3), or (4) above;

(6) been found civilly liable under a state or federal antitrust statute for acts or omission in connection with the submission of proposals or proposals for a public or private contract;

(7) admitted in writing or under oath, during the course of an official investigation or other proceeding, act or omissions that would constitute grounds for conviction or liability under any law or statute described above, except as follows [indicate reasons why the affirmation cannot be given, and list any conviction, plea, or imposition of probation before judgment with the date, court, official or administrative body, the sentence or disposition, the name(s) or the person(s) involved and their current positions and responsibilities with the Contractor, and the status of an debarment]:

D. AFFIRMATION REGARDING DEBARMENT

I FURTHER AFFIRM THAT:

Neither I, nor to the best of my knowledge, information, and belief, the above Contractor, or any of its officers, directors, partners, or any of its employees directly involved in obtaining or performing contracts with public bodies, has ever been suspended or debarred (including being issued a limited denial of participation) by any public entity, **except as follows** [list each debarment or suspension providing the dates of the suspension or debarment, the name of the public entity and the status of the proceedings, the name(s) of the persons(s) involved and their current positions and responsibilities with the Contractor, the grounds for the debarment or suspension, and the details of

each person=s involvement in any activity that formed the ground for the debarment or suspension];

E. AFFIRMATION REGARDING DEBARMENT OF RELATED ENTITIES

I FURTHER AFFIRM THAT:

1. The business was not established and it does not operate in a manner designed to evade the application of or defeat the purpose of debarment pursuant to Section 16-101, et seq., of the State Finance and Procurement Article of the Annotated Code of Maryland; and
2. The business is not a successor, assignee, subsidiary, or affiliate of a suspended or debarred business, **except as follows** [indicate the reason(s) why the affirmations cannot be given without qualification]:

F. SUB-CONTRACT AFFIRMATION

I FURTHER AFFIRM THAT:

Neither I, nor to the best of my knowledge, information, and belief, the above Contractor, has knowingly entered into a contract with a public body under which a person debarred or suspended under Title 16 of the State Finance and Procurement Article of the Annotated Code of Maryland will provide, directly or indirectly, supplies, services, architectural services, construction related services, leases of real property, or construction.

G. AFFIRMATION REGARDING COLLUSION

I FURTHER AFFIRM THAT:

Neither I, nor to the best of my knowledge, information, and belief, the above Contractor has:

1. Agreed, conspired, connived, or colluded to produce a deceptive show of competition in the compilation of the accompanying proposal or offer that is being submitted;
2. In any manner, directly or indirectly, entered into any agreement of any kind to fix the proposal price or price proposal of the bidder or offer of any competitor, or otherwise taken any action in restraint of free competitive bidding in connection with the contract for which the accompanying proposal or offer is submitted.

H. FINANCIAL DISCLOSURE AFFIRMATION

I FURTHER AFFIRM THAT:

I am aware of, and the above Contractor will comply with, the provisions of Section 13-221 of the State Finance and Procurement Article of the Annotated Code of Maryland, which require that every Contractor that enters into contracts, leases, or other agreements with the State of Maryland or its

agencies during a calendar year under which the Contractor is to receive in the aggregate \$100,000 or more shall, within thirty (30) days of the time when the aggregate value of the contracts, leases, or other agreements reaches \$100,000, file with the Secretary of State of Maryland certain specified information to include disclosure of beneficial ownership of the business.

I. POLITICAL CONTRIBUTION DISCLOSURE AFFIRMATION

I FURTHER AFFIRM THAT:

I am aware of, and the above Contractor will comply with the provisions of Article 33, Sections 30-1 through 30-4 of the Annotated Code of Maryland, which require that every person that enters into contracts, leases, or other agreements with the State of Maryland, including it=s agencies or a political subdivision of the State, during a calendar year under which the person receives in the aggregate \$100,000 or more shall, on or before February 1 of the following year, file with the Secretary of State of Maryland certain specified information to include disclosure of political contributions in excess of \$500 to a candidate for elective office in any primary or general election.

J. DRUG AND ALCOHOL FREE WORKPLACE

I CERTIFY THAT:

1. By submission of its proposal or offer, the Contractor, if other than an individual, certifies and agrees that, with respect to its employees to be employed under a contract resulting from this solicitation, the Contractor shall:

- (a) Maintain a workplace free of drug and alcohol abuse during the term of the contract;
- (b) Publish a statement notifying its employees that the unlawful manufacture, distribution, dispensing, possession, or use of drugs, and the abuse of drugs or alcohol is prohibited in the Contractor=s workplace and specifying the actions that will be taken against employees for violation of these prohibitions;
- (c) Prohibit its employees from working under the influence of drugs or alcohol;
- (d) Not hire or assign to work on the contract anyone whom the Contractor knows, or in the exercise of due diligence should know, currently abuses drugs or alcohol and is not actively engaged in a bona fide drug or alcohol abuse assistance or rehabilitation program;
- (e) Promptly inform the appropriate law enforcement agency of every drug-related crime that occurs in its workplace if the Contractor has observed the violation or otherwise has reliable information

that a violation has occurred;

(f) Establish drug and alcohol abuse awareness programs to inform its employees about;

(i) The dangers of drug and alcohol abuse in the workplace;

(ii) The Contractor's policy of maintaining a drug and alcohol free workplace;

(iii) Any available drug and alcohol counseling, rehabilitation, and employee assistance programs; and

(iv) The penalties that may be imposed upon employees who abuse drugs and alcohol in the workplace;

(g) Provide all employees engaged in the performance of the contract with a copy of the statement required by subsection 2(b), above;

(h) Notify its employees in the statement required by subsection 2(b), above, that as a condition of continued employment on the contract, the employee shall:

(i) Abide by the terms of the statement; and

(ii) Notify the employer of any criminal drug or alcohol abuse conviction for an offense occurring in the workplace not later than 5 days after a conviction;

(i) Notify the Procurement Officer within ten (10) days after receiving notice under subsection 2(h)(ii), above, or otherwise receiving actual notice of a conviction;

(j) Within 30 days after receiving notice under subsection 2(h)(ii), above, or otherwise receiving actual notice of a conviction, impose either of the following sanctions or remedial measures on any employee who is convicted of a drug or alcohol abuse offense occurring in the workplace;

(i) Take appropriate personnel action against an employee, up to and including termination; or

(ii) Require an employee to satisfactorily participate in a bona fide drug or alcohol abuse assistance or rehabilitation program; and

(k) Make a good faith effort to maintain a drug and alcohol free workplace through implementation of subsection 2(a)-(j), above.

2. If the Contractor is an individual, the individual shall certify and agree as set forth in subsection 4, below, that the individual shall not engage in the unlawful manufacture, distribution, dispensing, possession, or use of drugs or the abuse of drugs or alcohol in the performance of the contract.

K. CERTIFICATION OF CORPORATION REGISTRATION AND TAX PAYMENT

I FURTHER AFFIRM THAT:

1. The Contractor named above is a domestic _____, foreign _____, corporation registered in accordance with the Corporations and Associations Article, Annotated Code of Maryland, and that it is in good standing and has filed all of its annual reports, together with filing fees, with the Maryland State Department of Assessments and Taxation, and that the name and address of its resident agent filed with the State Department of Assessments and Taxation is:

Name _____

Address _____

(If not applicable, so state)

2. Except as validly contested, the Contractor has paid, or has arranged for payment of, all taxes due the State of Maryland and has filed all required returns and reports with the Comptroller of the Treasury, the State Department of Assessment and Taxation, and the Department of Economic and Employment Development, as applicable and will have all withholding taxes due the State of Maryland prior to final settlement.

L. CONTINGENT FEES

I FURTHER AFFIRM THAT:

The Contractor has not employed or retained any person, partnership, corporation, or other entity, other than a bona fide employee or agent working for the Contractor, to solicit or secure the contract, and that the Contractor has not paid or agreed to pay any person, partnership, corporation, or other entity, other than a bona fide employee or agent, any fee or any other consideration contingent on the making of the contract.

M. ACKNOWLEDGMENT

I ACKNOWLEDGE THAT this Affidavit is to be furnished to the Procurement Officer and may be distributed to units of (1) the State of Maryland; (2) counties or other subdivisions of the State of Maryland; (3) other states; and (4) the federal government. I further acknowledge that this Affidavit is subject to applicable laws of the United States and the State of Maryland, both criminal and civil, and that nothing in this Affidavit or any contract construed to supersede, amend, modify, or waive, on behalf of the State of Maryland or any unit of the State of Maryland having jurisdiction, the exercise of any statutory right or remedy conferred by the Constitution and the laws of Maryland with respect to any misrepresentation made or any violation of the obligations, terms, and covenants undertaken by the above Contractor with respect to (1) this Affidavit, (2) the contract, and (3) other Affidavits comprising part of the contract.

I DO SOLEMNLY DECLARE AND AFFIRM UNDER THE PENALTIES OF PERJURY THAT THE CONTENTS OF THIS AFFIDAVIT ARE TRUE AND CORRECT TO THE

BEST OF MY KNOWLEDGE, INFORMATION, AND BELIEF.

Date: _____

By: _____

(Authorized Representative and Affiant)

Appendix 3

CONFLICT OF INTEREST AFFIDAVIT AND DISCLOSURE

A. "Conflict of interest" means that because of other activities or relationships with other persons, a person is unable or potentially unable to render impartial assistance or advice to the State, or the person's objectivity in performing the contract work is or might be otherwise impaired, or a person has an unfair competitive advantage.

B. "Person" includes a bidder, offeror, contractor, consultant, or subcontractor or subconsultant at any tier, and also includes an employee or agent of any of them if the employee or agent has or will have the authority to control or supervise all or a portion of the work for which a bid or offer is made.

C. The bidder or offeror warrants that, except as disclosed in § D, below, there are no relevant facts or circumstances now giving rise or which could, in the future, give rise to a conflict of interest.

D. The following facts or circumstances give rise or could in the future give rise to a conflict of interest (explain details-attach additional sheets if necessary):

E. The bidder or offeror agrees that if an actual or potential **conflict of interest** arises after the date of this **affidavit**, the bidder or offeror shall immediately make a full disclosure in writing to the procurement officer of all relevant facts and circumstances. This disclosure shall include a description of actions which the bidder or offeror has taken and proposes to take to avoid, mitigate, or neutralize the actual or potential conflict of interest. If the contract has been awarded and performance of the contract has begun, the contractor shall continue performance until notified by the procurement officer of any contrary action to be taken.

I DO SOLEMNLY DECLARE AND AFFIRM UNDER THE PENALTIES OF PERJURY THAT THE CONTENTS OF THIS AFFIDAVIT ARE TRUE AND CORRECT TO THE BEST OF MY KNOWLEDGE, INFORMATION, AND BELIEF.

Date: _____ By: _____ (Authorized Representative and Affiant)

Appendix 4

CONTRACT AFFIDAVIT

AUTHORIZED REPRESENTATIVE

I HEREBY DECLARE AND AFFIRM that I am the (Title) _____,
and the duly authorized representative of
(Contractor) _____, and that I possess the legal
authority to make this Affidavit on behalf of myself and the Contractor for which I am acting.

2. CERTIFICATION OF CORPORATION REGISTRATION AND TAX PAYMENT

I FURTHER DECLARE AND AFFIRM that the Contractor named above is a domestic _____
foreign _____ (check one) corporation registered in accordance with the Corporations and
Associations Article, Annotated Code of Maryland, and that it is in good standing and has filed
all its annual reports, together with filing fees, with the Maryland State Department of
Assessments and Taxation, and that the name and address of its resident agent filed with the
State Department of Assessments and Taxation is:

Name: _____
Address: _____

(If not applicable, so state)

I FURTHER CERTIFY that, except as validly contested, the Contractor has paid or has arranged
for payment of all taxes due to the State of Maryland and has filed all required returns and
reports with the Comptroller of the Treasury, the State Department of Assessments and Taxation,
and the Employment Security Administration, as applicable, and will have paid all withholding
taxes due to the State of Maryland prior to final settlement.

**I DO SOLEMNLY DECLARE AND AFFIRM UNDER THE PENALTIES OF PERJURY
THAT THE CONTENTS OF THIS AFFIDAVIT ARE TRUE AND CORRECT TO THE
BEST OF MY KNOWLEDGE, INFORMATION, AND BELIEF.**

(Date) By: _____
(Affiant)

Appendix 5

B. Concensys® Product Specifications

A. Tackable Acoustic Panels

- Panels are constructed of 16-gauge, four-sided welded tubular steel frame.
- Panel top caps and end covers are extruded aluminum. Baseraill covers are steel.
- Top cap styles are painted (low profile or cableway) and wood veneer (low profile).
- Panels are 2-1/8" thick.
- Panels are available in 5 nominal heights (32", 43", 56", 69" and 82") and 7 widths (18", 24", 30", 36", 42", 48" and 60"). Actual height depends on top cap selected. (Nominal heights with low profile top cap are 30", 41", 54", 67", and 80")
- Panels are designed to wrap standard size components.
- Base panels accept stacking fabric and glass panels.
- Acoustic panels have Class A fire rating.
- Acoustic panels meet or exceed BIFMA acoustic guidelines and GSA requirements for acoustic panels.
- Panels are UL listed and labeled.
- All panels meet or exceed ANSI/BIFMA standards.
- Leveling glides provide 2" of vertical adjustment.
- All panels 24"-60" wide are designed to accept electrical components/receptacles.

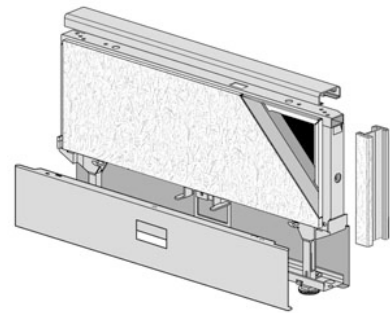

B. Technology Panels

- Panels are constructed of 16-gauge, four-sided welded tubular steel frame.
- Panel provides capacity for vertical and horizontal cable management.
- Panel surfaces are removable to allow easy access to electrical and data cabling and to speed installation.
- Each technology panels has two factory installed, color-matched knockouts per ported side for either electrical or data capability.
- Available in standard Concensys fabrics and trim options.
- Visually coordinates with other panel types.
- Technology Panels are available in 43", 56" and 69" nominal heights and 24", 30", 36", 42"

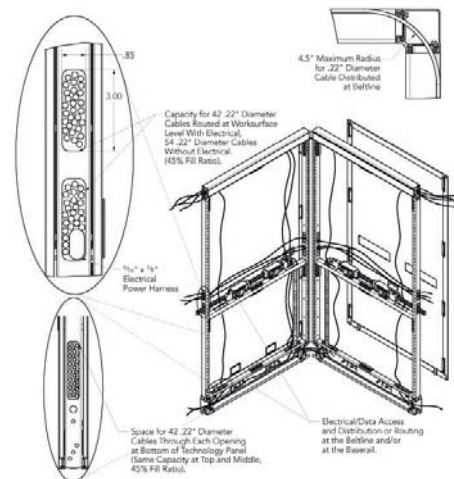

and 48” widths.

- Technology Panels can be field ported (with proper tools and use of model number CDP) to allow additional data ports.

C. Panels – Panel Styles

All panel styles coordinate visually, using the same connection method.

Stacking Panels

- Stacking panels are 13” high. Available in fabric or glass.
- Panels are constructed of 16-gauge, four-sided welded tubular steel frame.
- Stack up to 2 levels high on any Concensys base panel or door.
- Glass stacking panels feature clear, double pane, tempered safety glass inserts.
- Stacking panels are structural on the first level when specified according to Allsteel guidelines.

Pass-Thru Panels

- Bottom of pass-thru opening is 30-1/8” above floor level.
- Width of the pass-thru opening is 7” less than the panel width.
- Baseraill accepts electrical components.

Glazed Panels

- Available in full glazed or half-glazed.
- Glass is clear, double pane tempered safety glass.
- Baseraill accepts electrical components.
- Bottom of glass on half-glazed is 29-1/2” above floor level with levelers fully retracted.

Panel Door/Locksets

- Door is shipped Right-Handed but can be field changed to Left-Handed.
- Specify in place of an 82”H and 42”W panel (can be wall-mounted).
- Height of door is 77-3/4” and access width is 36”.
- Door surface is a solid-colored, high-pressure laminate, color matched or coordinated with all paint trim colors.
- A standard lock with a 2-3/4” setback is available; a lever handle is also available.

Non-Tackable Panels

- Available in all standard heights and widths.
- Interchangeable with Tackable Acoustic Panels.
- Baseraill accepts electrical components.
- Use as a lower cost alternative where sound absorption is not required.

D.

E. Panel Connectors

- Connectors provide rigid, full length metal-to-metal connection
- Connector kits include all parts required for connecting and finishing –top bracket, vertical fabric covered filler, lower base plate filler, top cap trim and necessary screws.
- “ELL”, “CROSS”, “TEE” and Extended Straight connections will add 2-1/4” to overall length of the panel run.

F. Electrical and Data

- Concensys panels are UL 1286 listed.
- Electrical components are UL listed and CSA certified.
- Concensys offers a choice of four electrical systems: **Four-circuit, 3 + 1; Four-circuit, 2 + 2; Three-circuit, separate neutrals; Eight circuits**, two four circuit systems provided back to back. All four systems utilize an 8-wire electrical system, rated at 20 amps per circuit (U.S.).
- Electrical power harness accepts 2 duplex receptacles per panel side, 4 total per panel (2 total on 24”W).
- Baseraill power in-feed mounts into any receptacle location in the baseraill area and is connected to the building power supply by a qualified electrician.
- Fiber optic and other data cabling can be routed through 90°.
- Capacity for lay-in cabling is provided at baseraill, and underneath ‘Cableway’ panel top cap.
- Data faceplates can be mounted in vacant receptacle openings.
- Integrated power pole accommodates power in-feed and communication/data lines.

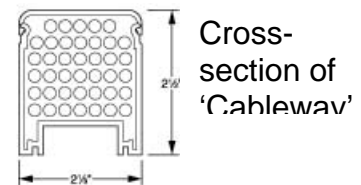
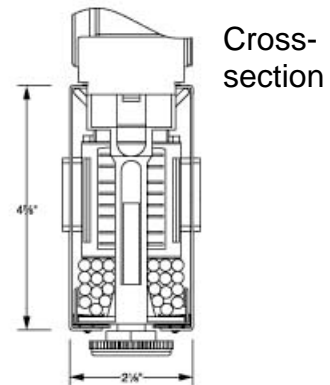

G. Worksurfaces

- Worksurfaces are 1-1/4” thick and meet or exceed ANSI/BIFMA standards.
- Worksurfaces are 3 ply construction with high-pressure laminate surface, particleboard core, and a resin-impregnated backer on the underneath side.
- Available in 3 edge options; T-Mold, PVC or radius.
- Threaded metal inserts are standard for ease of installation and a positive fit.
- Imbedded metal stiffener is standard on 48”W or wider surfaces to minimize deflection without interfering with below-surface storage.
- End panels and support legs are non-handed.

H.

I. Worksurface Styles

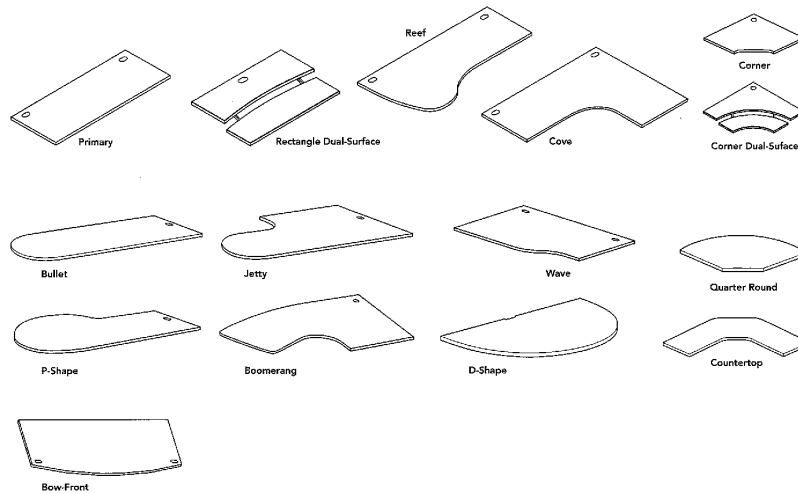

J. Overhead Storage

- Units are constructed of steel with a baked enamel surface.
- Units are standard with an anti-dislodgement device.
- Units are factory welded and pre-assembled.
- Inside clearance depth accommodates three-ring binders, and varies with type of door specified.
- Available door styles: Painted flipper door, fabric covered flipper door, Radius with no pull, Radius with arch pull, Radius mesh, and Receding door.
- Overhead cabinets can be mounted off-module on a panel up to 18” narrower than the overhead cabinet.
- Master keyed core removable locks allowing one-key access.

Pedestals

Persona™ Series Pedestals

- Constructed of 18-gauge steel outer shell.
- Features heavy-duty double “O” frame construction for added strength in keeping cabinet true to square.
- Master keyed core removable locks allowing one-key access.
- Counterweights (standard on all mobile units) inhibit tipping when drawers are opened.
- Double-wall drawer design. Drawer fronts are field replaceable.
- File compressors are included.
- Pencil tray included on models with box drawers.
- Mitered and beveled drawer fronts assure visual alignment when closed.
- Modular cabinet structure can be field reconfigured to any drawer combination.

- Can be converted from freestanding to mobile, or from mobile to freestanding.
- Full-extension file and box drawers glide easily on steel ball-bearing suspensions.
- Meets or exceeds all ANSI/BIFMA testing standards.

Essentials™ Series Pedestals

- Constructed of 20-gauge steel outer case.
- Full steel construction.
- Full extension file drawers with steel ball-bearing suspensions available.
- Master keyed with core removable locks allowing one-key access. Can be specified to omit lock core.
- Double-walled drawer design.
- Meets or exceeds all ANSI/BIFMA testing standards.

Lateral Files

Persona™ Series Lateral Files

- Steel front posts are formed with eight formations to provide unparalleled stability and strength.
- Drawers and doors lock on both sides to prevent being pried open.
- The dual-lock mechanism inhibits rollout of more than one drawer or shelf, either sequentially or simultaneously.
- Fully enclosed steel bottom to help prevent moisture and dust from affecting the filed documents.
- Files have two knockouts on each side to allow for easy ganging of freestanding units to inhibit tipping.
- Leveling glides can be adjusted from outside or inside the case.
- Heavy-duty, telescoping ball-bearing Accuride suspension.
- Heavy-duty ball-bearing slide with European hinge has 72 ball bearings per opening.
- Core Removable Lock allows for key numbers to be easily changed in the field. Lock core can also be omitted.
- Double-wall drawer front construction.
- Drawer interiors are painted the same color as the case.

Essentials™ Lateral Files

- Drawers and doors lock on both sides to prevent being pried open.
- Interlock system inhibits rollout of more than one drawer, either sequentially or simultaneously.
- Double bottoms are welded into all files for added rigidity.
- Leveling glides can be adjusted from outside or inside the case.

- Telescoping, ball bearing slides.
- Core removable lock feature allows key numbers to be easily changed in the field. Lock core can also be omitted.
- Files have two knockouts on each side to allow for easy ganging of freestanding units to inhibit tipping.
- Durable baked enamel finish is applied over rust-inhibiting phosphate pre-treatment. Drawer interiors and all accessories are painted gray.
- Counterweights included and factory-installed as required.